

SUGGESTED PLACEMENT FOR WHITE METAL CASTINGS AND ACCESSORIES

TRACKSIDE VIEW

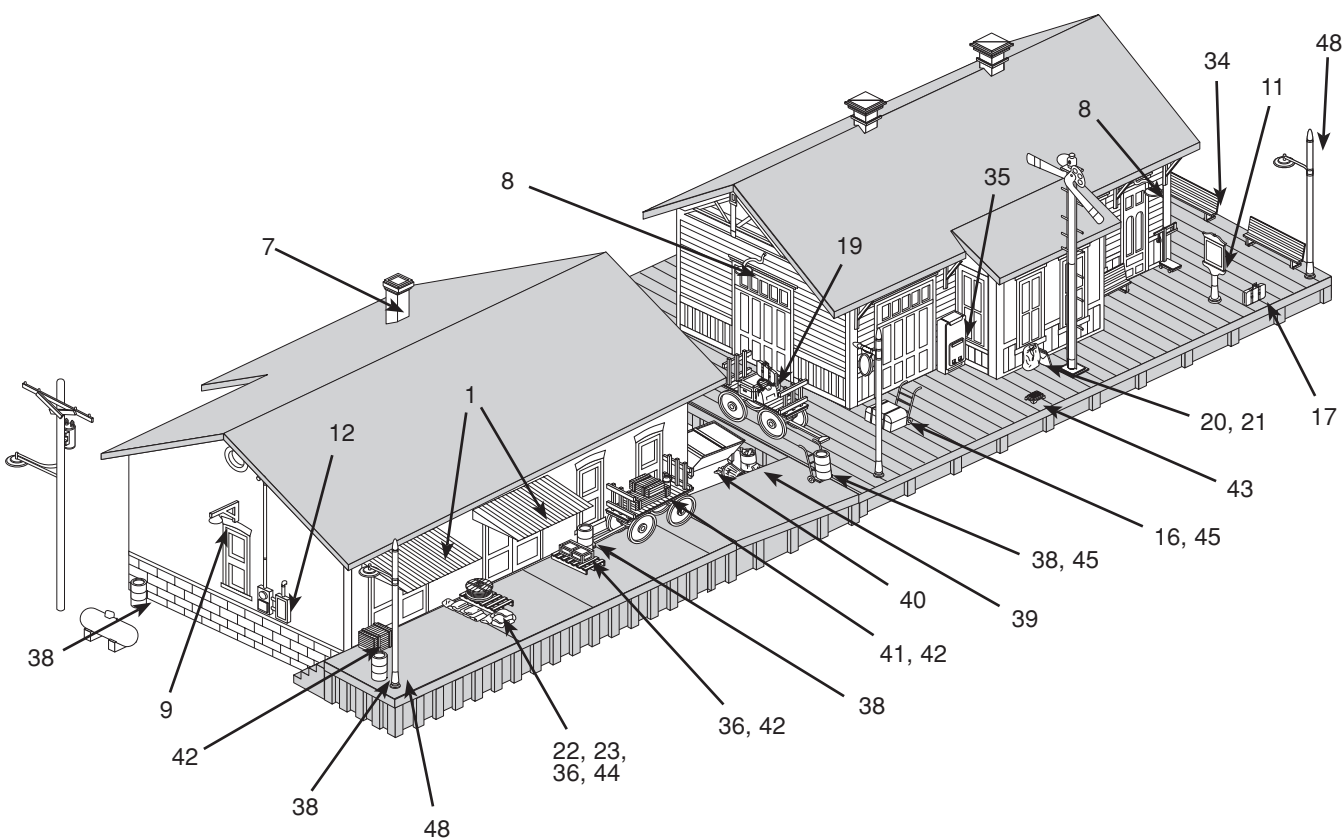

CURBSIDE VIEW

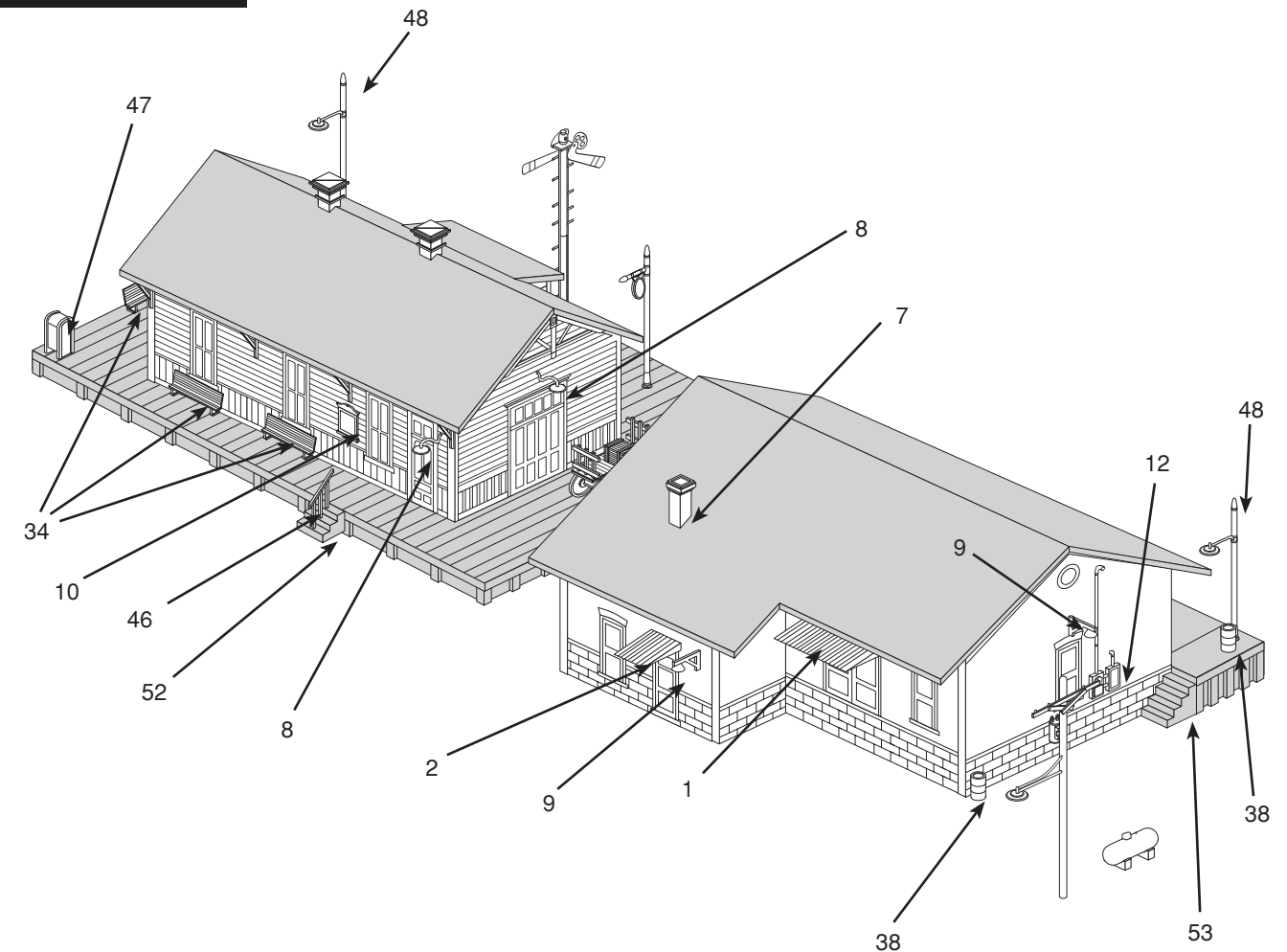

#405 COAL RIVER PASSENGER AND FREIGHT DEPOTS INSTRUCTIONS



Manufactured by **WOODLAND®**
 P.O. BOX 98
 LINN CREEK, MO 65052 USA
 woodlandscenics.com

MADE IN USA

Q11 ©1999 O CO

PREPARATION OF PARTS

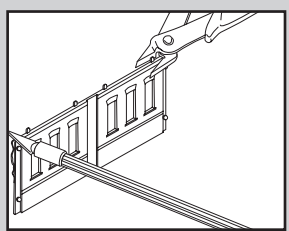

Use a hobby knife or diagonal cutters (i.e. Fiskars) to remove excess plastic created by molding process. Do not cut into details.

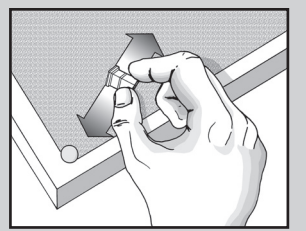
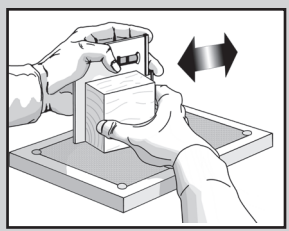

Sand draft angles (left from molding process) from edges of all the molded parts until edges are flat. Tack 100 grit sandpaper to flat surface. Make sanding area longer than the longest wall of the models. Using squaring block, keep edges flat and hold panels square as you sand. Move wall panel, not the block. Sanding is essential to achieve proper fit later. Be careful not to sand into detail of buildings. Lightly sand or file the smooth sides and bottom of chimneys for a proper fit.

To glue styrene walls and plastic pieces use plastic model cement or solvent.

PAINTING AND DETAILING

PAINTING

We recommend airbrushing with solvent-based enamel paints, such as Floquil, or a flat finish. Use water soluble flat paint such as Polly 'S' for brushing (color is your choice). See photo on box for suggested coloring. Paint roofs in flat tones and vary colors to resemble weathering and enhance shingle detail. Color of window and door frames can match or contrast with building. Building may be aged with chalks or lightly misted by airbrushing with thinned flat black paint such as Floquil Grimy Black. Small details painted in contrasting colors will enhance the building's appearance. See the photo on the box for painting ideas. Scrape paint from glue points as necessary. Walls and other parts may be painted before assembling. If buildings are painted after assembly, be careful not to paint over the clear window material.

OPTIONAL IDEA

To complete the illusion that buildings are occupied, place black paper (included in this kit) diagonally from corner to corner inside buildings to block light from entering.

DRY TRANSFER DECALS

- A. Place dry transfer decals in locations shown on front of package or where desired.
- B. Place sheet with decal pressed against surface. Hold sheet firmly so decal will not move while applying. Rub top of sheet over desired decal with a burnisher or dull pencil.
- C. Carefully remove decal sheet. If transfer was incomplete, let sheet fall back into place and repeat procedure.
- D. Place backing paper over decal and reburnish. Repeat with other decals.

TIP: If decals are fragmented they can still be used, this adds a realistic, weathered look.

NOTE: The cast details and Dry Transfers in this kit were made by Woodland Scenics for DPM Landmark Structures. See the entire line of Woodland Scenics Dry Transfers and castings at your favorite hobby store.

WHITE METAL CASTINGS & PARTS LIST:

The following list contains all details included with the 40500 kit. After cutting parts from sprues, sort and organize them. This will make assembly easier.

	Part No.	Name	Qty.		Part No.	Name	Qty.	
AWNINGS	1	Large	3	MISC. DETAILS	34	Benches	5	
	2	Small Awning	1		35	Soda Machine	1	
UTILITY LIGHT POLES	3	Poles	2	36	Pallets	3		
	4	Light Fixtures	2	37	Trash Cans	2		
	5	Cross Braces	2	38	Single Barrels	3		
	6	Transformer	1	39	Trash Can Grouping	1		
	BUILDING DETAILS	7	Chimney	1	40	Dumpster	1	
		8	Lights	3	41	Milk Jug	1	
9		Lights w/brackets	3	42	Crates	5		
10		Schedule Board	1	43	Passenger Step Stools	2		
11		Standing Schedule Board	1	44	Cable Roll	1		
12		Power Meter	1	45	Hand Truck	1		
CLOCK		13	Clock Face	1	46	Hand Rail	1	
		14	Pole	1	47	Mailbox	1	
LUGGAGE		15	Luggage Trunk	1	48	Decorative Light Poles	2	
		16	Trunk w/Rounded Top	1	HYDROCAL BASE	49	Wooden Platform	1
		17	Single Suitcase	1		50	Concrete Ramp	1
	18	Handbag	1	51		Freight Dock	1	
	19	Luggage Grouping	1	52		Stairs	1	
	20	Mail Bag	1	53		Stairs	1	
	21	Mail Pouch	1	PROPANE TANK	54	Propane tank	1	
22	7 Sack Grouping	1	55		Bases	2		
SEMAPHORE	24	Post	1	FREIGHT DEPOT		Styrene plastic walls	6	
	25	Flags	2		PASSENGER DEPOT		Styrene plastic parts	24
BAGGAGE CARTS	26	Handles	2	ADDITIONAL MATERIALS INCLUDED:				
	27	Platforms	2	Styrene Plastic Roof material - 1 (3 13/16" X 6 7/16") 1 (2 5/16" X 6 7/16")				
	28	Guards	4	Clear window material - 1 (5" X 5")				
	29	Wheels	8	Black paper - 2 (4 1/2" X 7 3/4")				
	30	Front Axles	2	Styrene Plastic stick - 1 (7")				
	31	Rear Axles	2	Styrene Plastic strips - 4 (7")				
SCALE	32	Base	1	Black and White Depot Signage sheet - 1				
	33	Post	1	Dry Transfer decal sheet - 1				
				Full Color Poster sheet - 1				

FREIGHT DEPOT INSTRUCTIONS:

1. Cut clear window material slightly larger than window frames. Attach window material to inside of model walls as shown in exploded diagram with a very small amount of glue placed around outer edges. Experienced modelers may do this step last.
2. Glue walls together as shown in exploded diagram. Make sure brick details match. Apply glue to inside seams of walls.
3. Sand bottoms of assembled walls over sandpaper in circular motion to make sure structure sits level (FIG. 1). Turn building upside down and sand top edges of both slopes to ensure that roof fits without gaps (FIG. 2).
4. To start roof assembly measure and draw 1 3/8" x 3" rectangle directly on largest styrene sheet as shown (FIG. 3).
5. Use straightedge and hobby knife to cut out marked rectangular area.
6. Cut 7" styrene plastic stick to 5 1/2" length to form Ridge Support (FIG. 4).
7. Glue Ridge Support to large roof segment 1/16" from edge that will be the roof peak. (FIG. 5).
8. Glue edge of remaining short roof segment against Ridge Support under edge of large roof segment as shown in FIG. 6. Make sure side edges of both roof segments are aligned to each other.
9. Glue assembled roof to walls by running a bead of glue down inside seam where roof and walls meet.
10. Using a file (or sandpaper) remove overlap of roof until an even peak is formed (FIG. 7).
11. Use Roof Trim Board patterns (FIG. 6) to mark approximate sizes on the thin styrene plastic strips furnished. Match and file end angles on strips 1-3 to fit pattern. Check fit to roof edges. Glue Trim Boards to roof edges (FIG. 8).

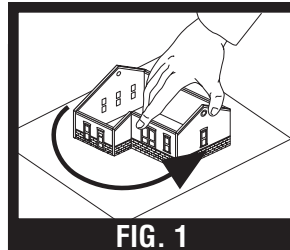

FIG. 1

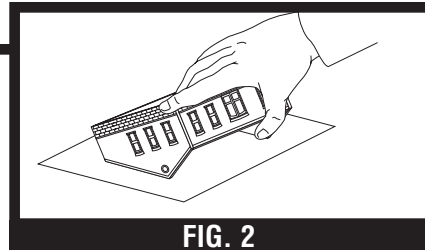

FIG. 2

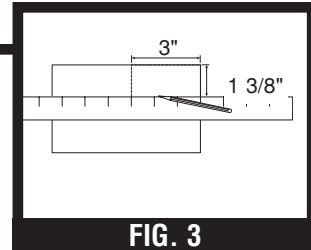

FIG. 3

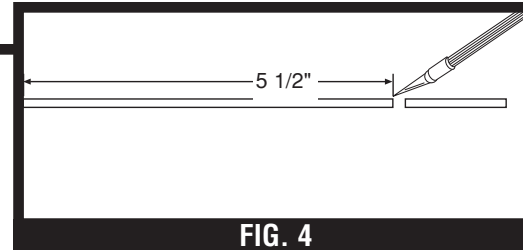

FIG. 4

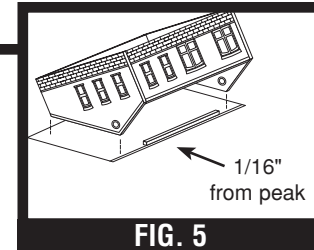

FIG. 5

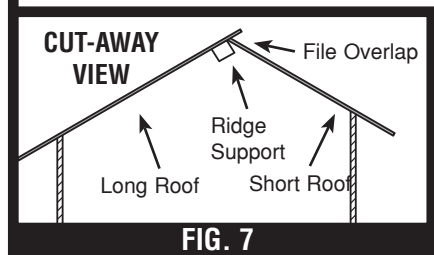

FIG. 7

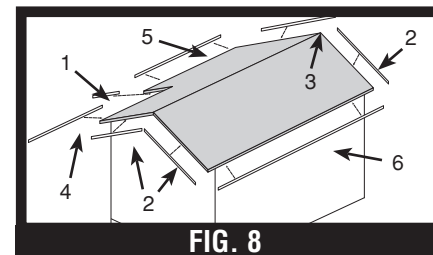

FIG. 8

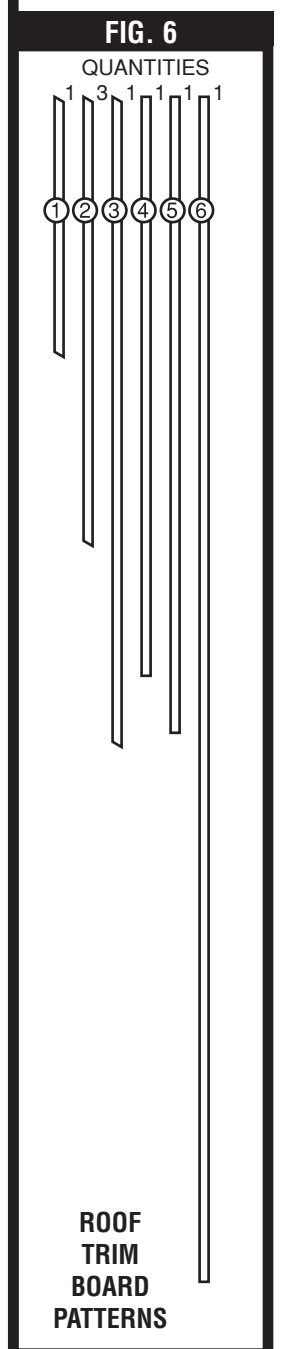
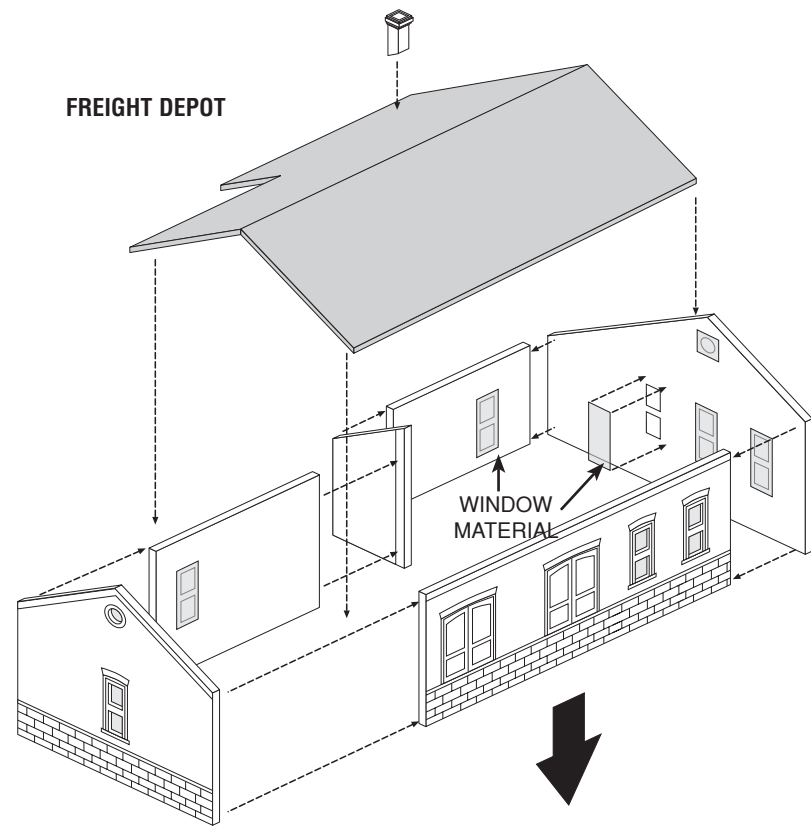
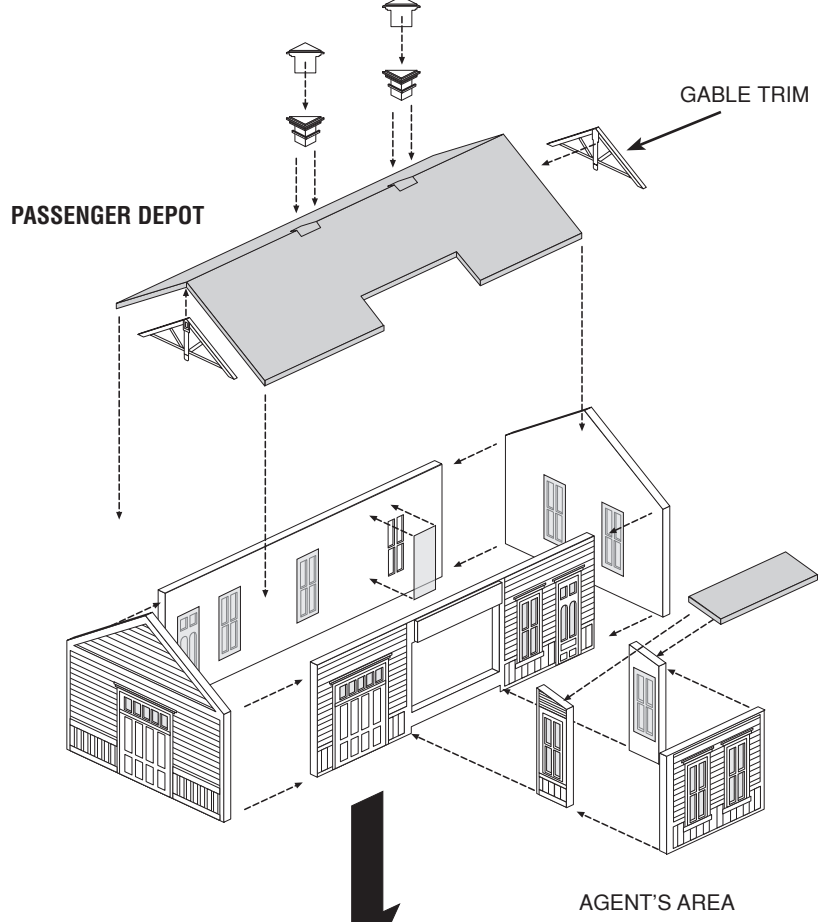

FIG. 6
QUANTITIES



FREIGHT DEPOT

WINDOW MATERIAL



PASSENGER DEPOT

GABLE TRIM

AGENT'S AREA

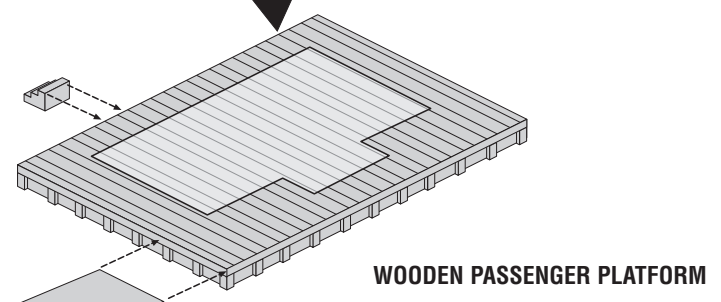

WOODEN PASSENGER PLATFORM

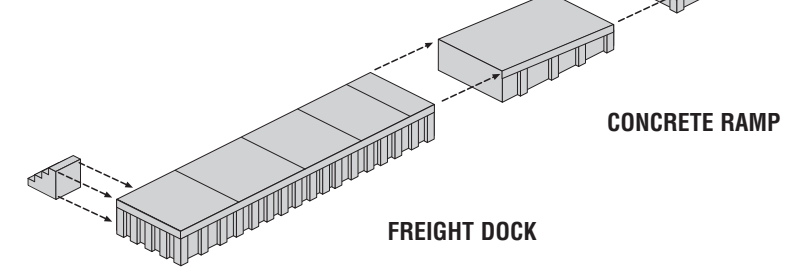

CONCRETE RAMP

FREIGHT DOCK

PASSENGER DEPOT INSTRUCTIONS:

1. Cut clear window material slightly larger than window frames. Attach window material to inside of model walls as shown in exploded diagram with very small amount of glue placed around edges. Experienced modelers may do this step last.
2. After window material is glued in place, cut curtains and shades from strips of masking tape as shown in Fig. 9. Pieces can be cut slightly larger than window panes. Position curtain pieces over window material on the inside of walls as shown. See photo on box for suggested placement.
3. Before gluing make sure baseboard at bottoms of all walls align. Glue walls together as shown by running a bead of glue down a single contact point. Apply glue to inside seam of walls.
4. Sand bottoms of assembled walls over sandpaper in circular motion to make sure structure sits level.
5. Glue roof segments together by matching beveled edges. Place and glue Gable Trim under roof and flush with edges. Glue large roof to wall assembly.
6. Once large roof is attached, test fit small roof for Agent's area. Small roof should fit on top of walls for Agent's area with shingles running the same direction as shingles for large roof. Sand and test until satisfied with fit. Glue in place.
7. Glue 8 brackets to walls and under roof as shown (FIG 10). See Trackside View and Curbside View for placement.
8. Assemble and glue plastic chimneys. Glue chimneys to peak of roof as shown.

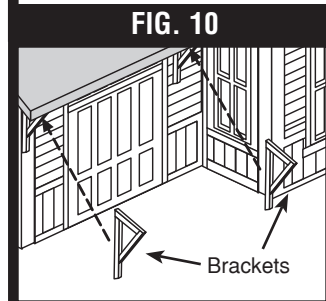

FIG. 10

Brackets

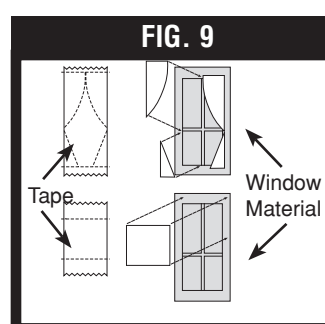

FIG. 9

Tape Window Material

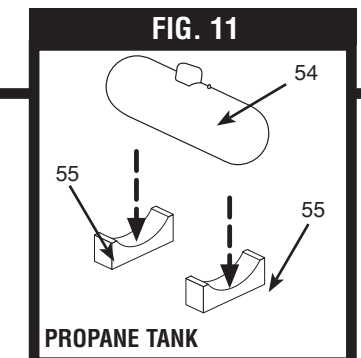

FIG. 11

PROPANE TANK

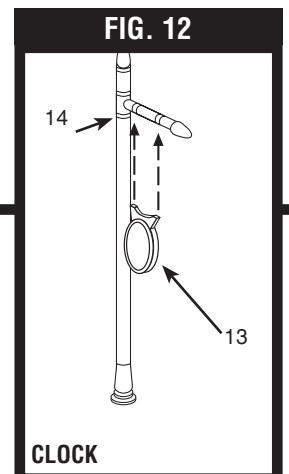

FIG. 12

CLOCK

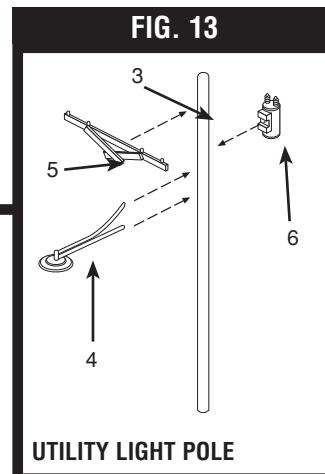

FIG. 13

UTILITY LIGHT POLE

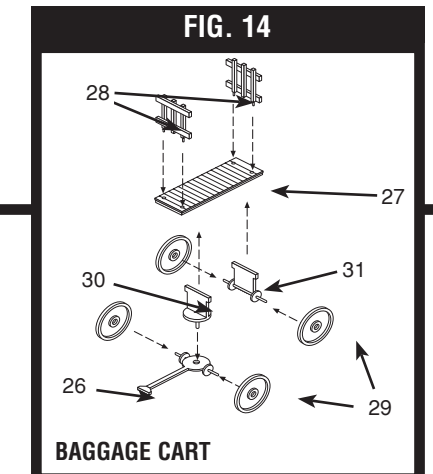

FIG. 14

BAGGAGE CART

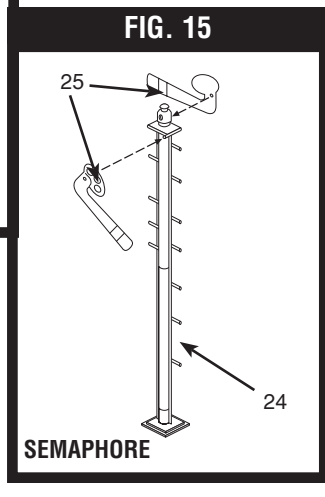

FIG. 15

SEMAPHORE

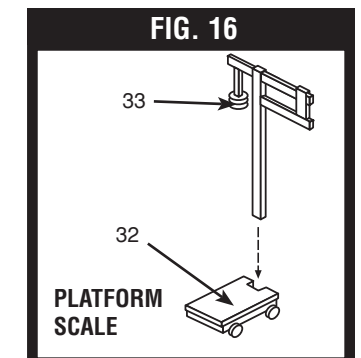

FIG. 16

PLATFORM SCALE

PLATFORM & DOCK INSTRUCTIONS:

1. Paint Hydrocal Platform, Ramp and Freight Dock with thinned washes of water-based paint. We recommend using Woodland Scenics Earth Colors including: Slate Gray (C1219) for concrete Freight Dock and Ramp, and Earth Undercoat (C1229) for Passenger Platform.
2. Sand butting ends of Hydrocal Platform, Ramp and Freight Dock. Assemble as shown in exploded diagram.
3. Glue stairs to platform in areas designated in illustration using white glue or cyanoacrylate ("super glue").
4. Center Passenger Depot on Passenger Platform with wood planks positioned as shown. Place Freight Depot behind Freight Dock in position shown in Trackside View illustration.

PREPARATION OF WHITE METAL CASTINGS:

Remove parting lines, flash and stems with a hobby knife (i.e., X-Acto), diagonal cutters (i.e., Fiskars), sandpaper or file. Test fit castings. Note: Castings bend easily and should be handled carefully. Straighten bent or warped castings.

Wash all metal castings in soapy water to remove residue caused by molding process. Rinse and allow parts to dry.

Plan ahead. It is often easier to paint certain castings before assembly. We recommend using a primer coat and then painting castings with a high quality, flat paint. If you paint, scrape paint from glue points before gluing and touch up paint if necessary after assembly. Glue castings together with a fast-setting epoxy or cyanoacrylate such as "super glue." (A thick, gap-filling cyanoacrylate is recommended.)

DETAIL INSTRUCTIONS:

1. Assemble white metal castings (FIGS. 11 - 16). Paint if necessary.
2. Apply decals as shown on box or where appropriate.
3. When painted details are dry, place them on layout. See Trackside illustration and photo on box for suggested placement.